

# Dual swing damper BR 22 KS

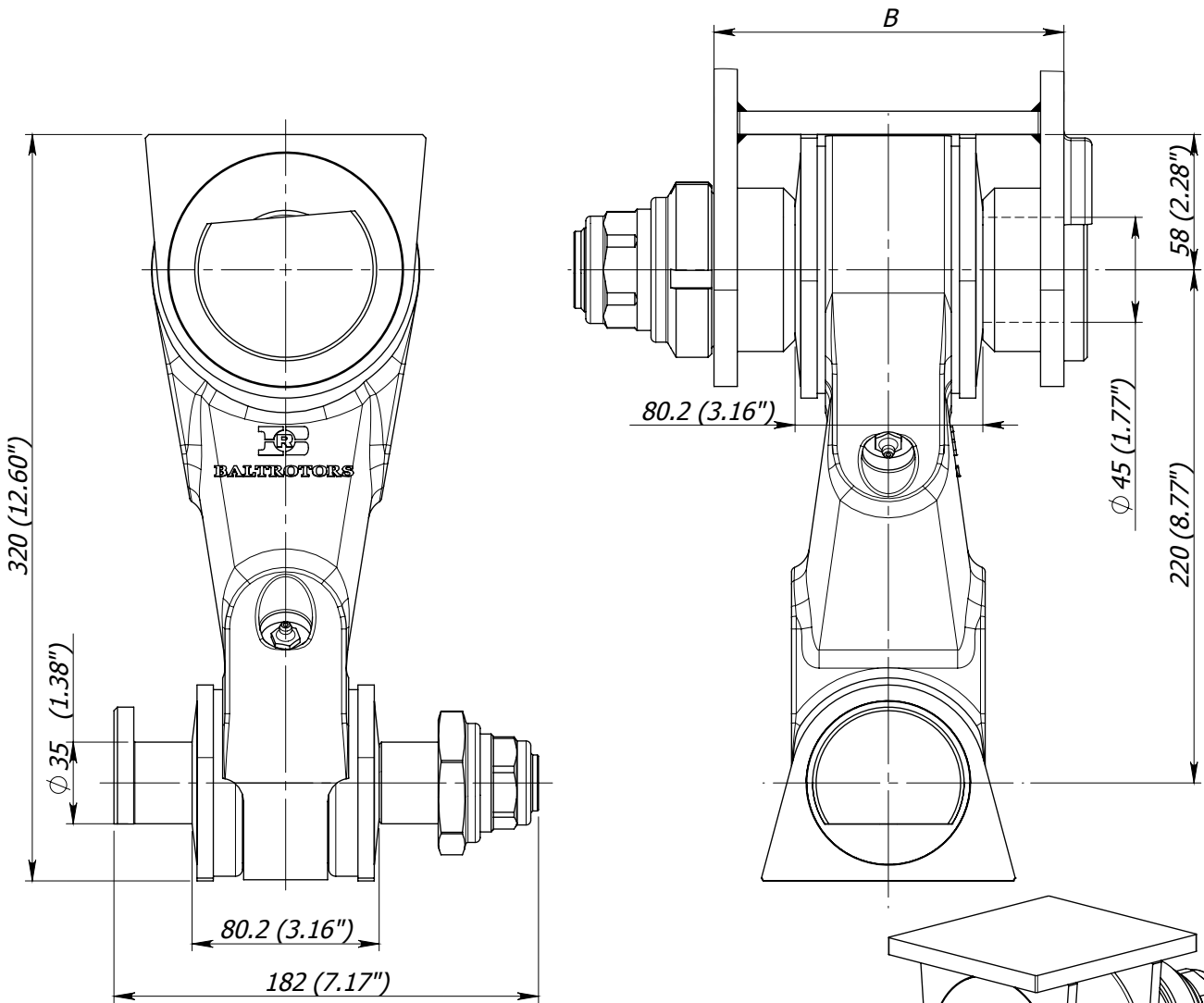

Link	Crane nose outer width B (mm)	Weight (kg)
BR 22 KS/170	170 (6.69'')	17.78 (39.20 lb)
BR 22 KS/160	160 (6.29'')	17.65 (38.91 lb)
BR 22 KS/150	150 (5.90'')	17.53 (38.64 lb)
BR 22 KS/140	140 (5.51'')	17.40 (38.36 lb)
BR 22 KS/130	130 (5.12'')	17.28 (38.09 lb)
BR 22 KS/120	120 (4.72'')	17.15 (37.80 lb)
BR 22 KS/110	110 (4.33'')	17.03 (37.54 lb)

**It is possible to change size B by client's request**

**Instruction manual**

To adjust the brake of the link, following actions have to be done:

- release the lock nut (pos.2)
- twist the adjusting nut (pos.1) until the disc spring starts to clamp
- tighten the adjusting nut (pos.1) at 1...1.5 turns, that will provide braking moment of 200...250 Nm (148...185 lb ft)
- tighten the lock nut (pos.2) with tightening torque 100 Nm (74 lb ft).

Greasing of lower slide bearing and brake cones is already done through lubricating nipple (pos.3). Fill grease

Starplex EP 2 until it will appear to the external surfaces.

Greasing must be repeated after every 8 working hours of the link.

**NOTICE! The link is delivered ungreased. It should be well greased before taking into exploitation.**

