

ROTATOR GRS16S-01

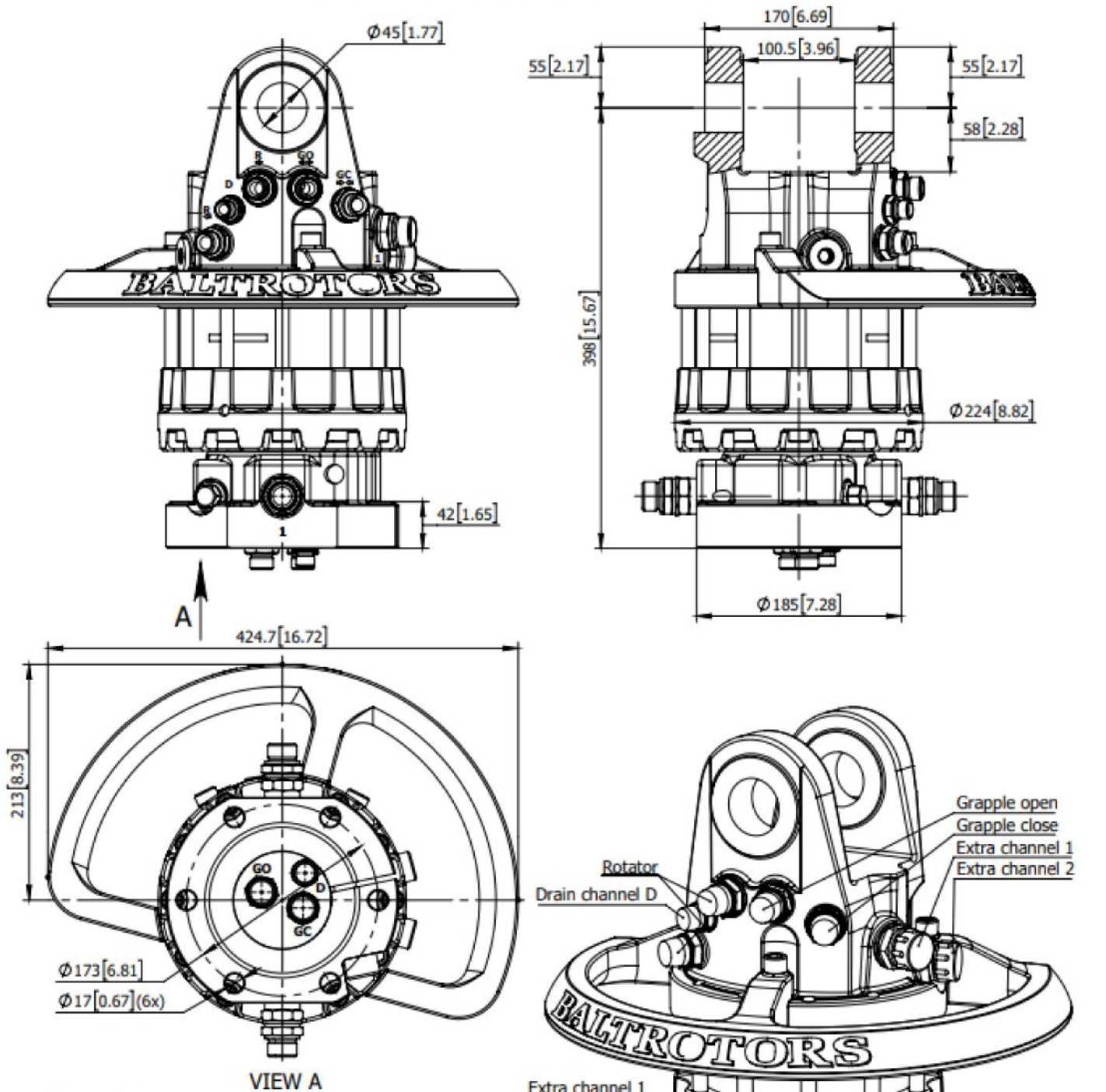

Technical data

Rotation	Unlimited
Max axial load static, kN (lbf)	+160 (35976) -90 (20236)
Max axial load dynamic, kN (lbf)	+80 (17988) -45 (10118)
Torque at 25Mpa (3625psi), Nm (lb ft)	3400 (2500)
Rec oilflow, l/min (US gallon)	40 (10.6)
Weight, kg (lb)	79 (175)
Max working pressure:	Connection:
Rotator	↔R↔ Max 25 MPa (3625 psi) G 1/2
Grapple / Tool open	↔G↔ Max 20 MPa (2900 psi) G 1/2
Grapple / Tool close	→G← Max 30 MPa (4350 psi) G 1/2
Extra oil function	1 2 Max 30 MPa (4350 psi) G 3/4
Drain channel D	D Max 10 MPa (1450 psi) G 3/8

